



***U.S. ARMY COMBAT CAPABILITIES
DEVELOPMENT COMMAND
GROUND VEHICLE SYSTEMS CENTER***

Modified NATO New Customer Orientation

POC: John.E.Hubble.civ@army.mil



contents



Specifications	3
.....	
Design of Test Scope	5
.....	
>> Test Procedure	6
.....	
>> Instrumentation	7
.....	
Test Request Process	8
.....	
Customer Supplied Info	9
.....	
Other Test Services	10
.....	

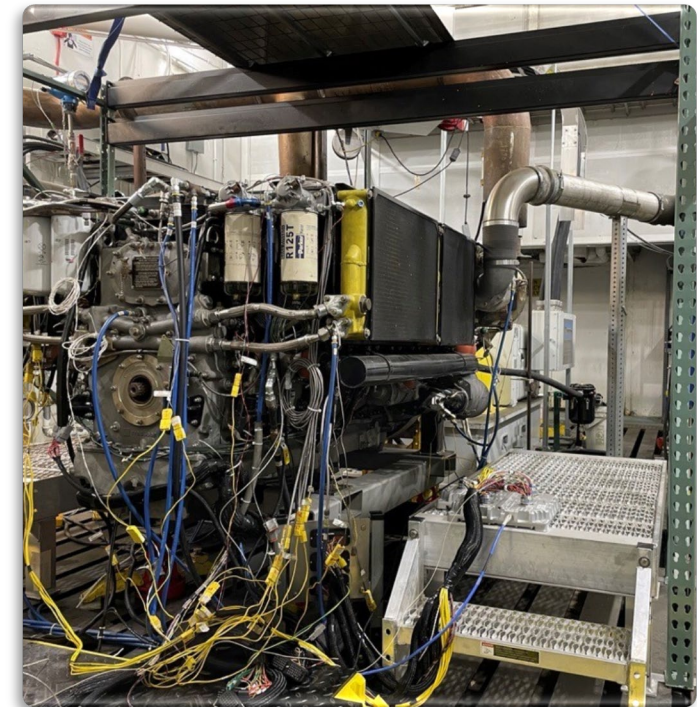



SPECIFICATIONS



Tactical Engines



Combat Engines

Propulsion Systems Laboratories (PSL) offers comprehensive engine testing capabilities specifically tailored to the rigorous demands of the AEP-5 NATO 400-hour test plan. We provide full-spectrum support, encompassing engine instrumentation, data acquisition, and control systems to accurately simulate operational profiles and stress conditions. PSL's facilities are equipped to conduct endurance runs, performance mapping, and detailed failure analysis, adhering strictly to AEP-5 protocols for data recording, reporting, and acceptance criteria. Our experienced engineering team manages all aspects of the test, from initial engine setup and baseline characterization to post-test teardown and comprehensive report generation, ensuring reliable and defensible results for engine qualification and certification according to NATO standards. We routinely support testing of various engine types and sizes, delivering consistent, high-quality data critical for evaluating long-term durability and operational readiness.



SPECIFICATIONS



Dynamometers

A/C Cells 1&8

- Speed: 0-5000 RPM Absorption
- Torque: 0-3000 lbf-ft Absorption
- Power: 0-1000 hp Absorption
- Speed: 0-5,500 RPM Motoring
- Torque: 0-2700 lbf-ft Motoring
- Power: 0-900 hp Motoring

General

- Chamber Door: 12 ft (W) x 12 ft (T)
- Size: 25 ft (W) x 20 ft (T) x 40 ft (L)
- Floor Capacity: 100 tons
- Crane: 5 tons
- Test Cell Fabrication Capabilities
- Fuel Measurement
- AV-900 Bidirectional Power Supply
- F24, DF-2 compatible

Environmental/Utilities

- Temperature: ambient to 160°F
- Wind: 0-5 mph
- Water: 900 gpm with 50 psig
- Electrical service and loading

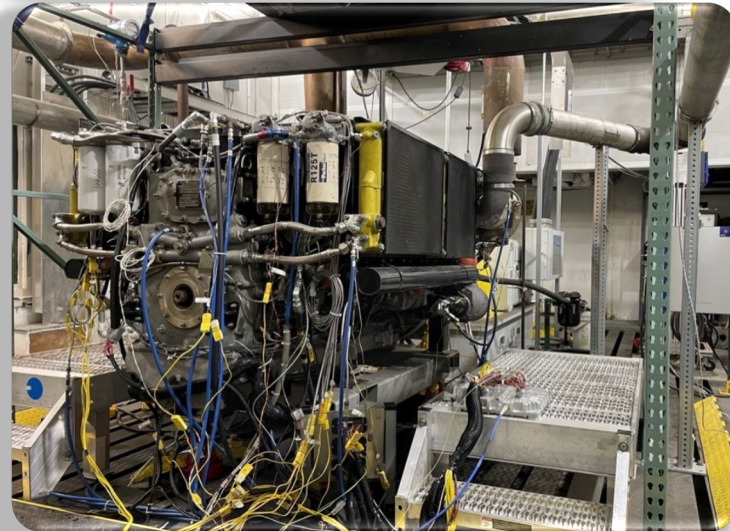



SPECIFICATIONS



Dynamometers

Eddy Current Cells 3 & 6

- Speed: 0-5000 RPM Absorption
- Torque: 0-13000 lbf-ft Absorption
- Power: 0-2000 hp Absorption

General

- Chamber Door: 12 ft (W) x 12 ft (T)
- Size: 25 ft (W) x 20 ft (T) x 40 ft (L)
- Floor Capacity: 100 tons
- Crane: 5 tons
- Test Cell Fabrication Capabilities
- Fuel Measurement
- AV-900 Bidirectional Power Supply
- F24, DF-2 compatible

Environmental/Utilities

- Temperature: ambient to 160°F
- Wind: 0-5 mph
- Water: 900 gpm with 50 psig
- Electrical service and loading

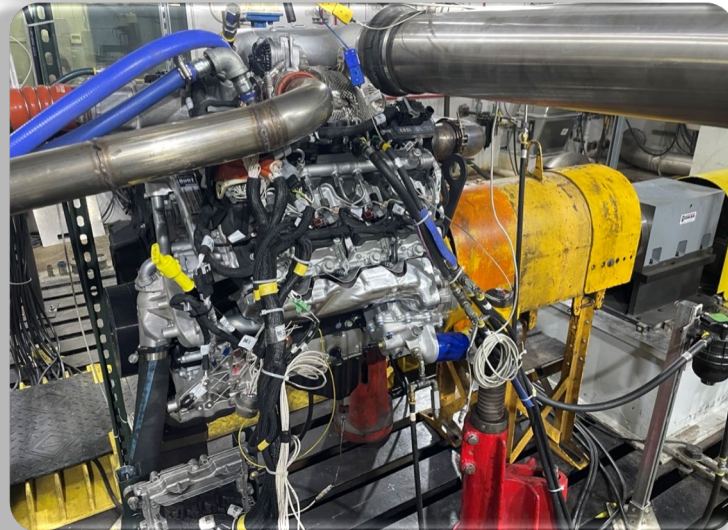



Design of test scope



In the early stages of a test program, defining the test scope is one of the most significant steps. The test scope is made up of two major components, test procedure and test instrumentation. The test procedure details the various methods and types of tests that will be used to evaluate the vehicle's performance. The test instrumentation determines the types of measurements and their locations that will need to be recorded during each segment of the test procedure. The test procedure and test instrumentation harmonize to answer the customer's information goal. Both are tailored to the level of complexity of the problem the customer is trying to solve. Ultimately, the test scope is the essential piece to providing a quote for test program cost.

Procedure

- How will the engine be tested?

Instrumentation

- What parameters will be measured?

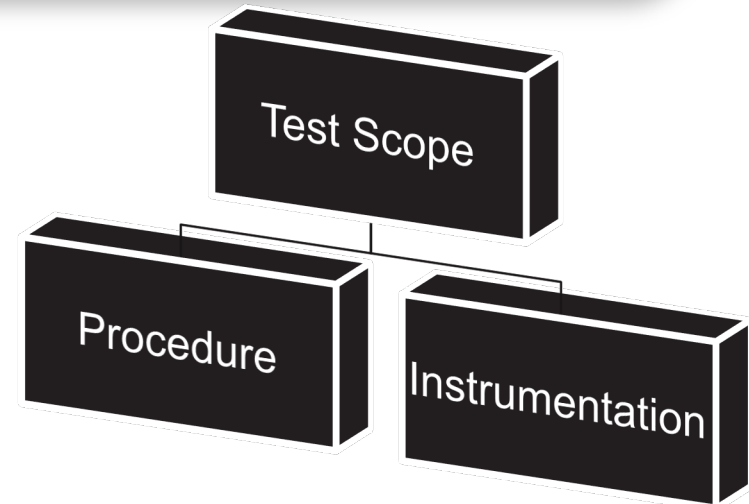



Design of test scope



09:15:09

Endurance Testing

- How many hours before engine failure.
- NATO 400hr



Performance Testing

- Does the engine deliver the advertised power
- SAE J1995
- SAE J1312 & SAE1349, Procedure For Mapping Engine Performance

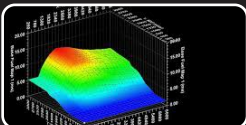

Fuel Mapping

- Does the engine utilize the fuel effectively to convert energy stored in the fuel to mechanical energy.
- SAE J1312 & SAE1349, Procedure For Mapping Engine Performance



Heat Rejection Mapping

- How much energy from the fuel and air gets converted into heat energy
- SAE J1312 & SAE1349, Procedure For Mapping Engine Performance



Engine Calibration Development

- Optimizing the engines performance on military F24 fuel to achieve the best possible balance of power and fuel efficiency



Engine Component Assessment

- Assess the engines operation durability with component upgrades or replacements



Customer Specific

- Planning, Testing, Research, Development

Customers also have the option to select test procedures from a standard set of mobility performance tests, supply a specific set of test procedures, or request recommendations from PSL based on their information goal.

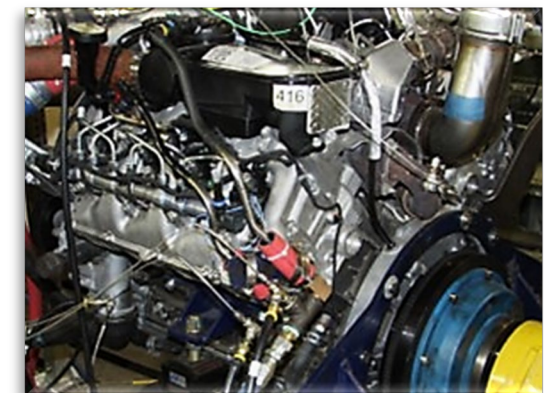
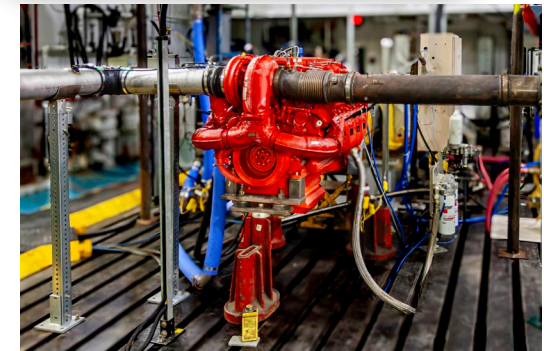



Design of test scope



Customers have the option to select a general level of test instrumentation, provide a specific set of instrumentation requirements, or request recommendations from PSL based on their information goal.

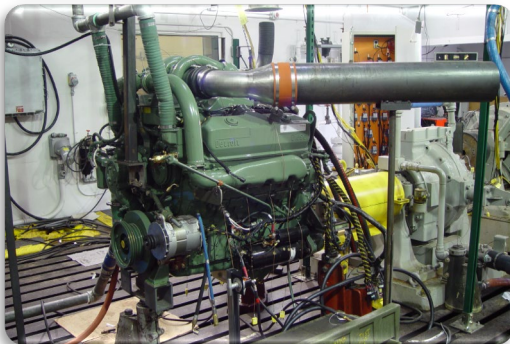
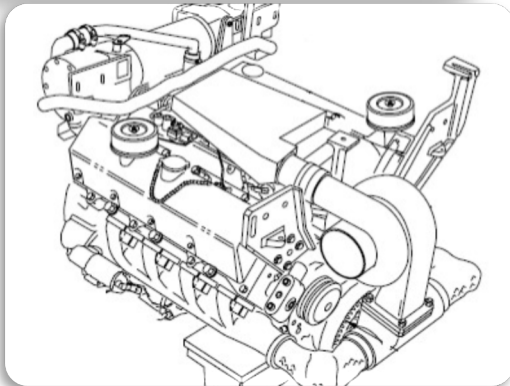

Essential

- Channels for health/safety monitoring only

Test Specific

- Additional channels added to study particular areas on the engine

Total Package

- CAN, temperatures, pressures, flow, voltages, currents, loads and speeds



Test Request Process



PSL can be booked 3-6 months in advance. Cancellations are very rare, but sometimes there is immediate availability. Estimated time varies significantly depending on the test scope.

4-8 weeks →

Test Planning

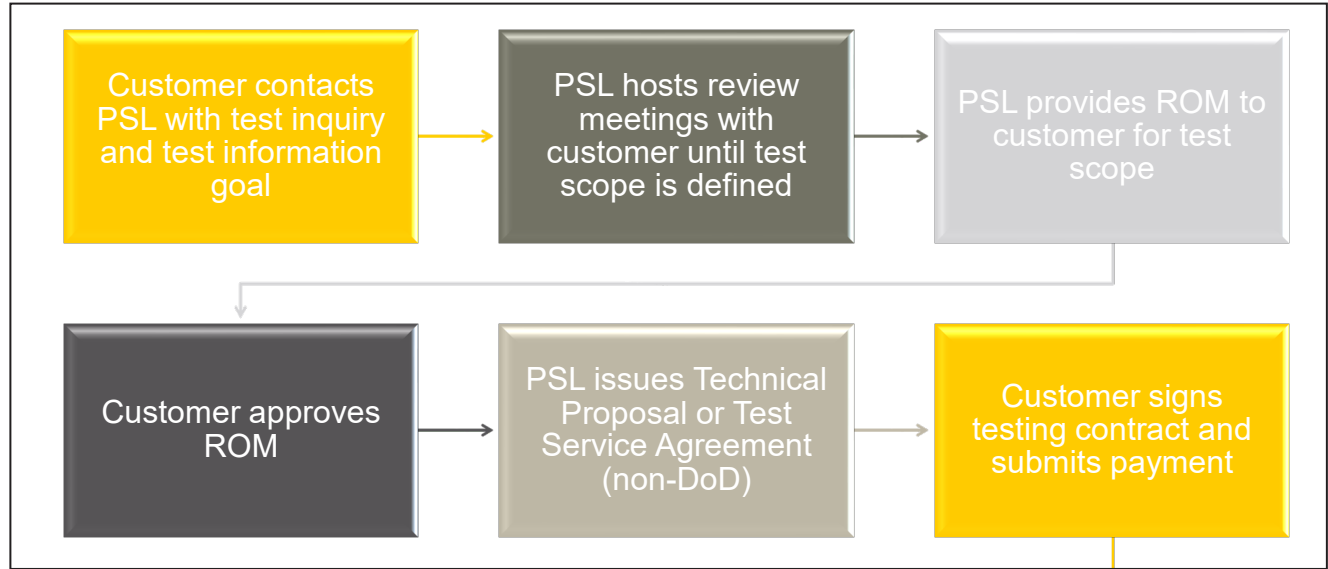

3-5 weeks →

Engine Setup

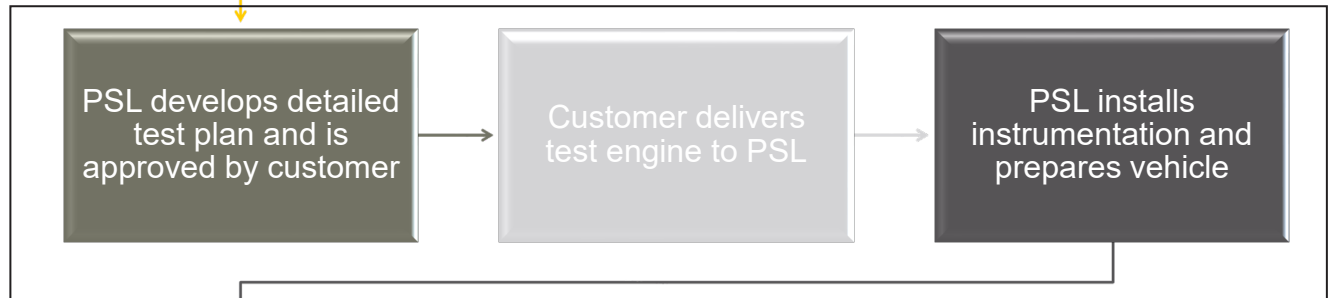

4-10 weeks →

Run Test





Customer supplied information



General Engine Data

- Type - 2 cycle/4 cycle etc.
- Configuration, V, I, etc
- Number of Cylinders
- Aspiration
- Bore & Stroke
- Displacement
- Compression Ratio
- Dry Weight
- Wet Weight
- Moment of Inertia of Rotating Components (Excluding Flywheel)
- Firing Order
- Maximum bending moment at rear face of block

In addition to supplying the test engine, the customer will also need to provide several data items (see example list) for instrumentation selection and dynamometer configuration.





Customer supplied information



Engine Air Induction System

- Compressor Inlet Diameter/Dimensions, inches
- Compressor Inlet Adaption Interface Flange and Clamping info.
- Maximum Inlet Restriction with Clean Filter
- Maximum Inlet Restriction with Dirty Filter
- Maximum Operating Ambient Air Temperature
- Require a Charge Air Cooler?
- Turbo Compressor Flange and Clamping info.

In addition to supplying the test engine, the customer will also need to provide several data items (see example list) for instrumentation selection and dynamometer configuration.

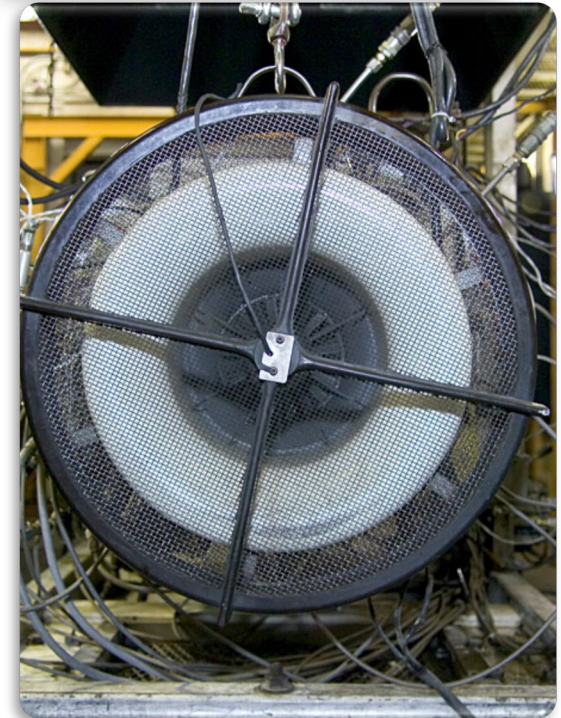



Customer supplied information



Engine Exhaust System

- Turbine Inlet Diameter/Dimensions
- Turbine Inlet Adaption Interface
- Maximum Back Pressure imposed by Piping and Silencer
- Exhaust Pipe size normally acceptable
- Maximum Bending Moment to the Turbocharger Exhaust Outlet Flange
- Turbo Turbine Flange and Clamp
- Exhaust Down Pipe

In addition to supplying the test engine, the customer will also need to provide several data items (see example list) for instrumentation selection and dynamometer configuration.

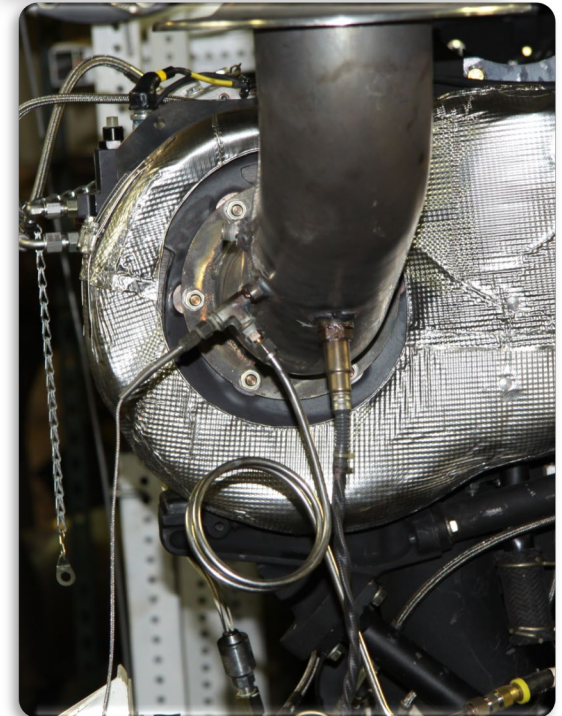



Customer supplied information



Engine Lubrication System

- Lubrication Engine Inlet/Outlet Diameter/Dimensions, inches
- Lubrication Line Adaptation interface
- Oil Pressure @ idle - Minimum
- Oil Pressure @ Max RPM - Range
- Total Pump Oil Flow @ Rated RPM (Nominal)
- Oil Capacity of Pan
- Total Oil System Capacity
- Maximum Allowable Oil Temperature
- Oil Filters and Housing Part Number
- Oil Type/Viscosity

In addition to supplying the test engine, the customer will also need to provide several data items (see example list) for instrumentation selection and dynamometer configuration.





Customer supplied information



Engine Cooling System

- Cooling Engine Inlet Diameter Dimensions
- Cooling Engine Outlet Diameter Dimensions
- Cooling Line - Adaptation Interface
- Coolant Capacity - Engine only
- Standard Modulating Thermostat
- Minimum Radiator Cap Pressure
- Maximum Coolant Temperature - Engine Out
- Minimum Recommended Coolant Temperature
- Minimum Fill Rate
- Minimum Coolant Expansion Space - % of System

In addition to supplying the test engine, the customer will also need to provide several data items (see example list) for instrumentation selection and dynamometer configuration.





Customer supplied information



Engine Fuel System

- Fuel System Inlet/Outlet Line - Diameter/Dimensions
- Fuel System Inlet/Outlet Line - Adaptation Interface
- Maximum Fuel Consumption at Maximum Rated Output and Speed, lb/hr, BSFC
- Maximum Fuel Supply Pressure to Injection Pump Inlet at Maximum Rated Output and Speed, lb/hr, BSFC
- Maximum Supply Fuel Flow to Pump at Maximum Rated Output and Speed
- Maximum Restriction @ Pump inlet - with Clean Filter
- Maximum Injector Return Line Restriction
- Fuel Filter and Housing Part Numbers
- Fuel Type (e.g. F24/DF-2)

In addition to supplying the test engine, the customer will also need to provide several data items (see example list) for instrumentation selection and dynamometer configuration.





Customer supplied information



Engine Ignition & Electrical System

- Electrical Schematic
- Throttle Voltage Span
- CAN Communication DBC file
- CAN Information Gathering
- ECU Pin Out
- Connector Type
- Required Power 12VDC, 24VDC, Hybrid 12VDC and 24VDC
- Type of Output and Span
- Dynamometer Harness
- Dynamometer Calibration

In addition to supplying the test engine, the customer will also need to provide several data items (see example list) for instrumentation selection and dynamometer configuration.





Customer supplied information



Engine Installation Drawings & Hardware

- Flywheel Crankshaft Interface Dimensions
- Engine Mount Interface Dimensions
- Engine Vibration Isolators/Rubber Mounts
- Horse Collar/Mounting Fixtures

In addition to supplying the test engine, the customer will also need to provide several data items (see example list) for instrumentation selection and dynamometer configuration.

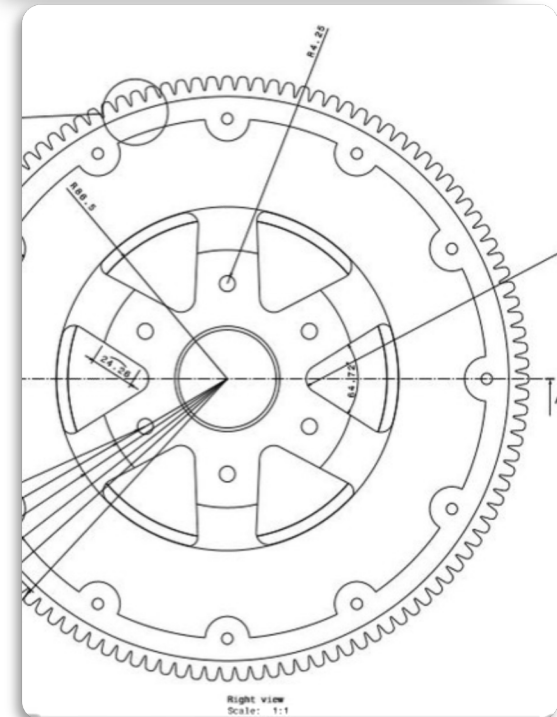



Customer supplied information



Engine General Performance Data

- Minimum Low Idle Speed
- Minimum No Load Governed Speed
- Maximum No Load Governed Speed
- Maximum Overspeed Capability
- Crankshaft Thrust Bearing Load Limit - Maximum Intermittent
- Crankshaft Thrust Bearing Load Limit - Maximum Continuous
- Peak Torque
- Peak Torque Speed

In addition to supplying the test engine, the customer will also need to provide several data items (see example list) for instrumentation selection and dynamometer configuration.

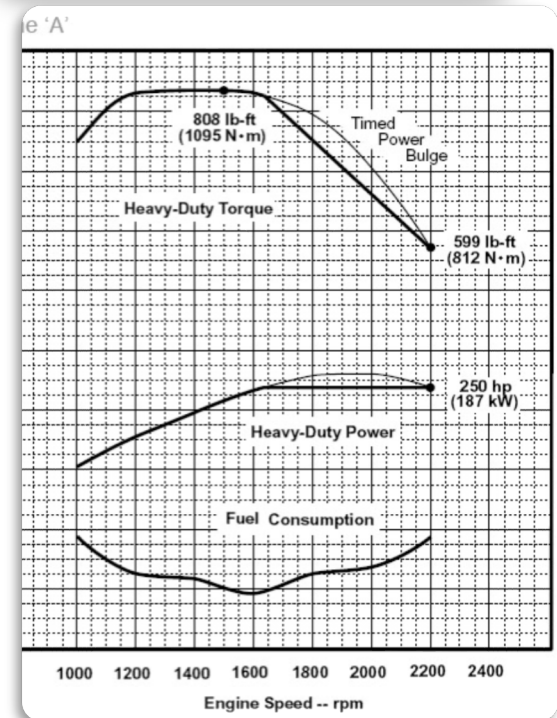



Customer supplied information



Engine Rated Performance Data

- Rated Power Output
- Rated Engine Speed
- Rated Torque
- Nominal Rail Pressure
- Intake Manifold Pressure
- Break Mean Effective Pressure
- Piston Speed
- Friction Horsepower
- Inlet Air Flow
- Exhaust Gas Flow
- Exhaust Gas Temperature
- Heat Rejection to Ambient
- Heat Rejection to Coolant
- Maximum Radiator Coolant Flow

In addition to supplying the test engine, the customer will also need to provide several data items (see example list) for instrumentation selection and dynamometer configuration.

Engine-Full power curves

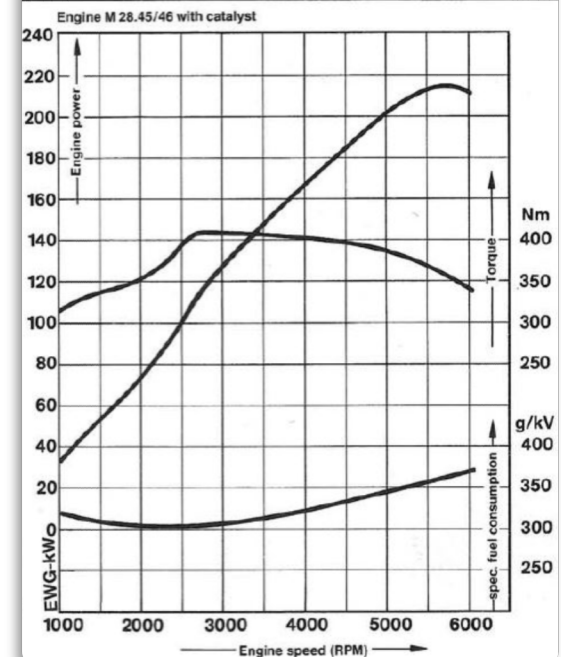



Other test services



Even if you are not testing in PSL, please ask us about our other testing services.

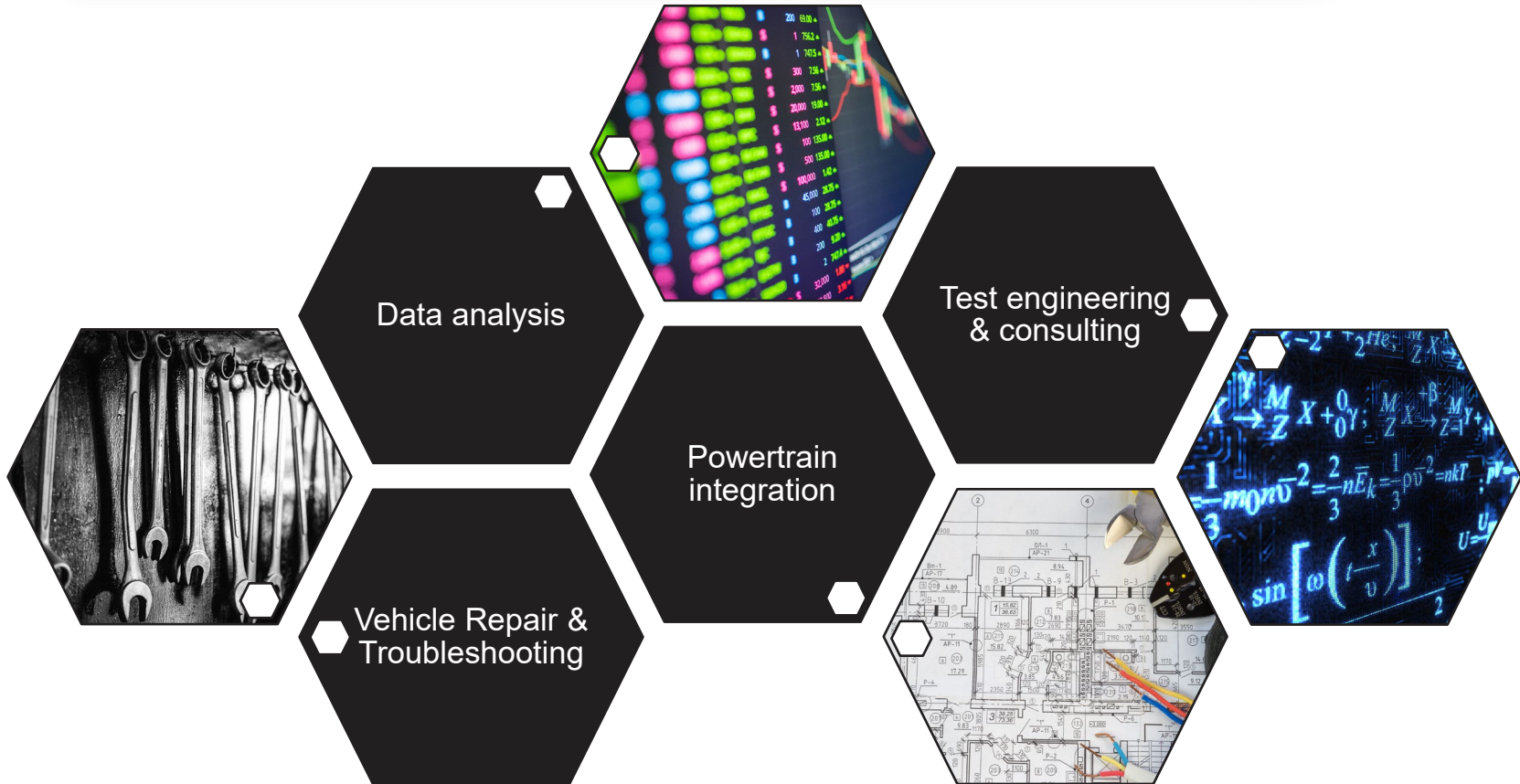

FOR FURTHER INFORMATION:

Dr. Igor Baseski, Division Chief T&I
e-Mail: igor.baseski.civ@army.mil
Phone: (586) 215-9327

John Hubble, PSL Branch Chief
e-Mail: John.E.Hubble.civ@army.mil
Phone: (586) 282-8532



ALWAYS MOVING

DEVCOM - Ground Vehicle Systems Center
6501 E. 11 Mile Road
Bldg 212 (FCDD-GVR-TI), MS-121
Warren, MI 48397-5000



GVPM Testing and Integration Website:

<https://gvsc.devcom.army.mil/gvpm/>

Reference herein to any specific commercial company, product, process or service by trade name, trademark, manufacturer or otherwise does not necessarily constitute or imply its endorsement, recommendation or favoring by the United States Government (USG) or Department of Army (DoA). The opinions of the authors expressed herein do not necessarily state or reflect those of the USG or DoA and shall not be used for advertising or product endorsement purposes.



U.S. ARMY